

Trailer Kits

Field Install Kit Instructions

- 8.917-558.0 Saddle Box Kit
- 8.917-559.0 Rock Guard Kit
- 8.917-560.0 Utility Rack Kit

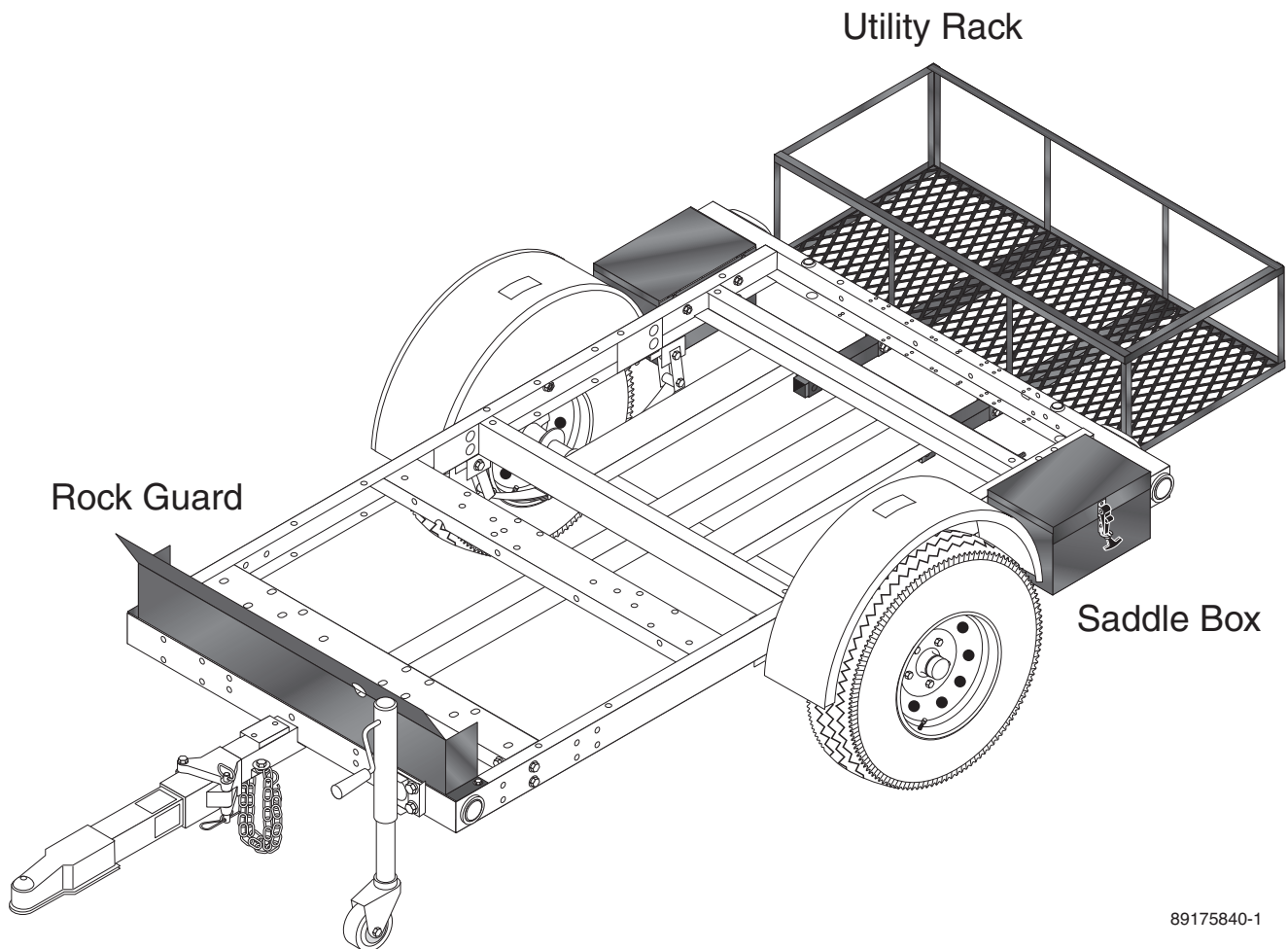

89175840-1

INSTALLATION INSTRUCTIONS

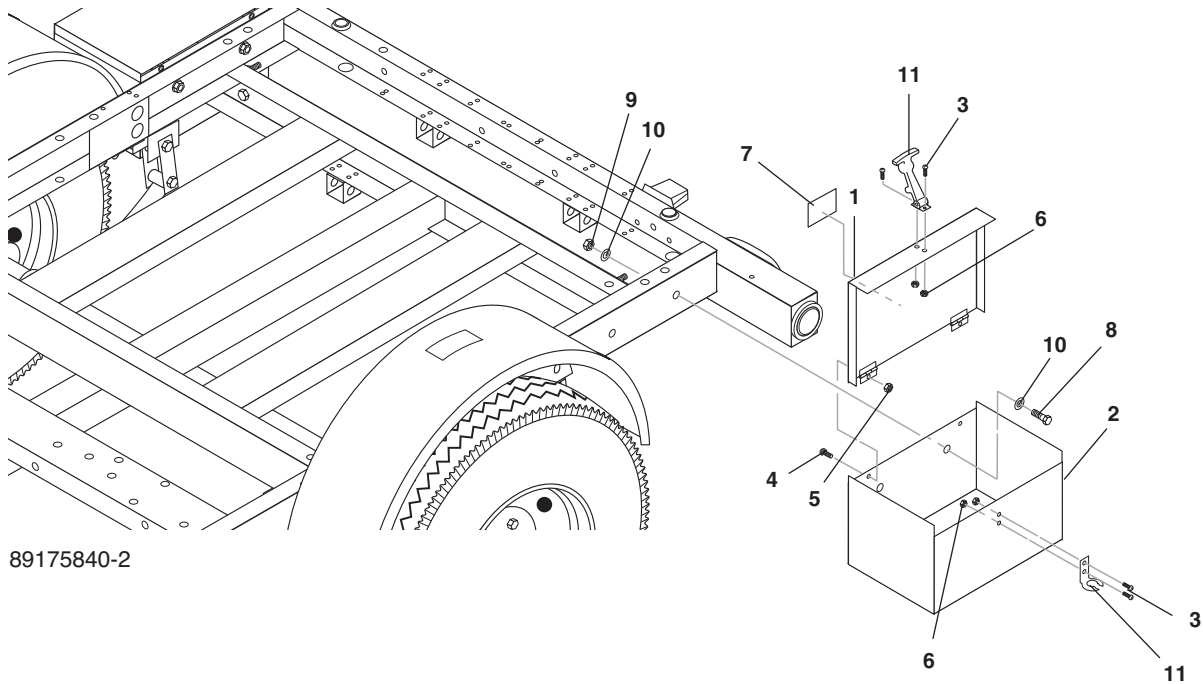

89175840-2

Saddle Box Kit Assembly and Installation Instructions # 8.917-558.0

Step 1

Attach keeper (item 11) to Box (item 2) using 6-32 Screw (item 3) and 6-32 Nut (item 6).

Step 2

Attach Handle (item 11) to Lid (item 1) using 6-32 Screw (item 3) and 6-32 Nut (item 6).

Step 3

Attach Lid (item 1) to Box (item 2) using 10-32 Screw (item 4) and 10-32 Nut (item 9).

Step 4

Attach assembled Box to Trailer using 3/8" Bolt (item 8), 3/8" Washer (item 10), and 3/8" Nut (item 9).

Step 5

Affix Do Not Stand or Step Label (item 7) to outside of Box Assembly.

ITEM	PART NO.	DESCRIPTION	QTY
1	8.917-308.0	WLMT, Lid, Trailer storage box	1
2	8.917-342.0	Box, Trailer Storage	1
3	8.718-733.0	Screw, 6/32" x 5/8", RND HB MCH"	4
4	8.718-760.0	Screw, 10/32"x 5/8" PHIL PAN, SS	2
5	9.802-696.0	*NUT, 10/32" NF ST ST KEP	2
6	9.802-779.0	*NUT, 6-32 KEPS	4
7	8.900-522.0	Label, Do Not Stand or Step	1
8	9.802-722.0	* Bolt, 3/8" x 1-1/4", NC HH	4
9	9.802-779.0	Nut 3/8"	2
10	9.802-807.0	Washer, 3/8" Flat	4
11	8.706-568.0	Handle, Rubber T, W/Keeper	1

Tools Required:

- 9/16" Socket or Wrench
- Phillips Head Screwdriver
- Flat Head Screwdriver
- 5/16" Socket or Wrench
- 3/8" Socket or Wrench

INSTALLATION INSTRUCTIONS

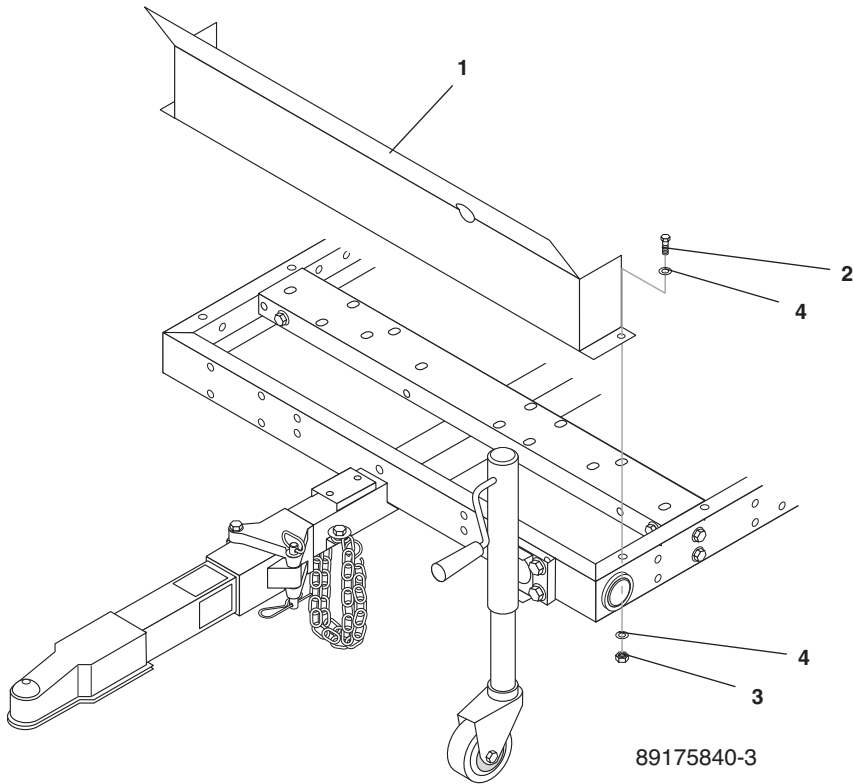

Rock Guard Kit Assembly and Installation Instructions # 8.917-559.0

Step 1

Attach Rock Guard (item 1) to Trailer using 3/8" Bolt (item 2), 3/8" Nut, and 3/8" Washer (item 4).

Tools Required:

9/16" Socket or Wrench

ITEM	PART NO.	DESCRIPTION	QTY
1	8.917-528.0	Shield, ROCK	1
2	9.802-722.0	*Bolt, 3/8" x 1 1/4", NC HH	2
3	9.802-799.0	Nut 3/8"	2
4	9.802-807.0	Washer, 3/8" FLAT	4

INSTALLATION INSTRUCTIONS

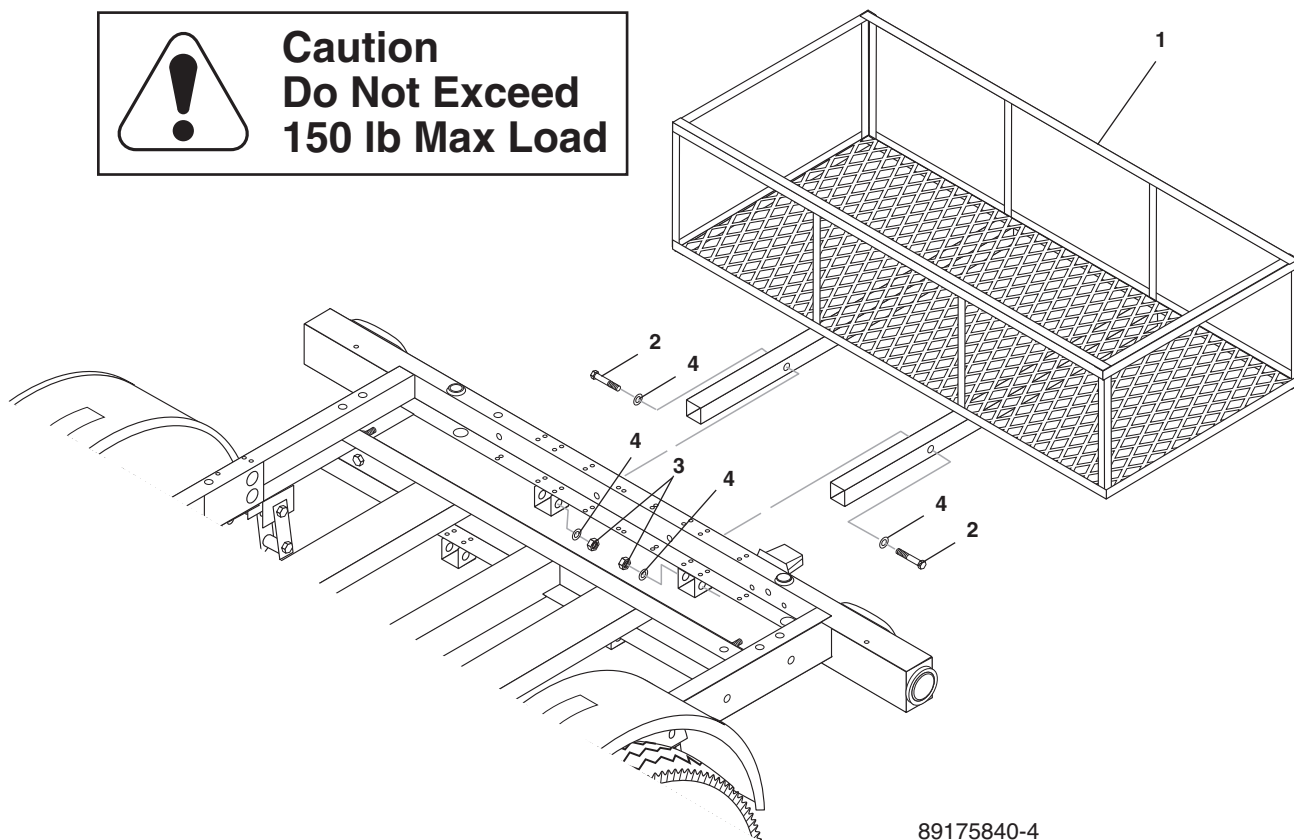

89175840-4

Utility Rack Kit Assembly and Installation Instructions # 8.917-560.0

Step 1

Slide mounting arms of the Utility Rack into dual receiver brackets at back of Trailer until mounting holes are aligned.

Step 2

Attach Utility Rack (item 1) to Trailer using 3/8" Bolt (item 2), 3/8" Nut (item 3), and 3/8" Washer (item 4).

ITEM	PART NO.	DESCRIPTION	QTY
1	8.917-307.0	WLMT, Rack, Utility	1
2	8.718-680.0	Bolt, 3/8" x 3 1/2", NC HH GR 5"	2
3	9.802-799.0	Nut 3/8"	2
4	9.802-807.0	Washer, 3/8" FLAT	4

Tools Required:

9/16" Socket or Wrench